

LTR	REVISION RECORD	ECN NO.	DRG	DATE
A	First Issue	RD13-0825001	King	8/25'13

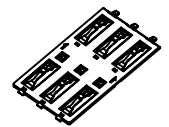

Reel with Product
10 Reel

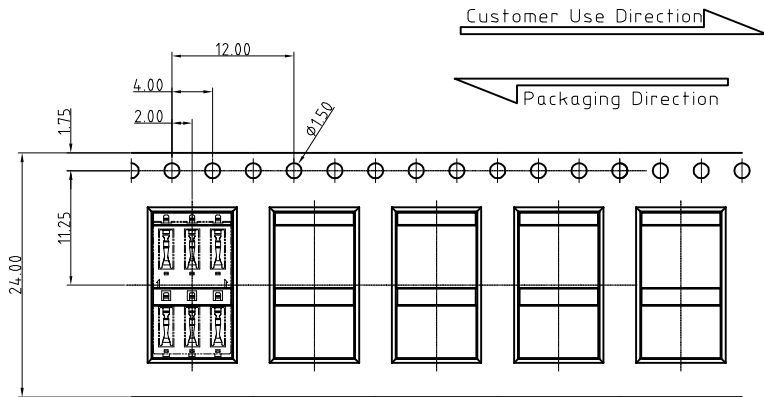
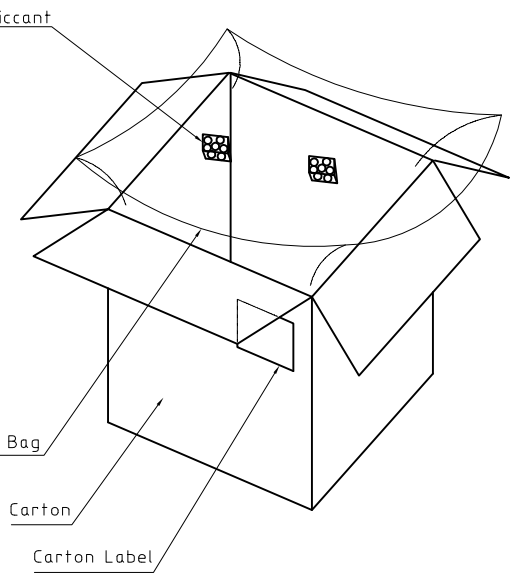
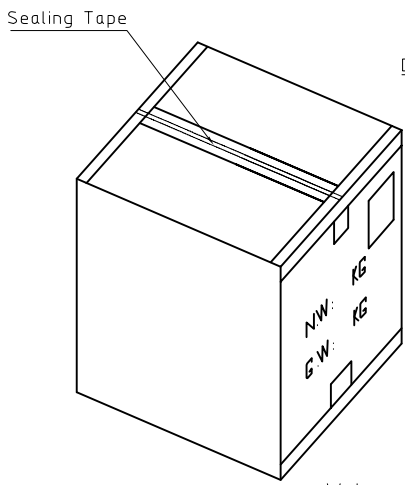
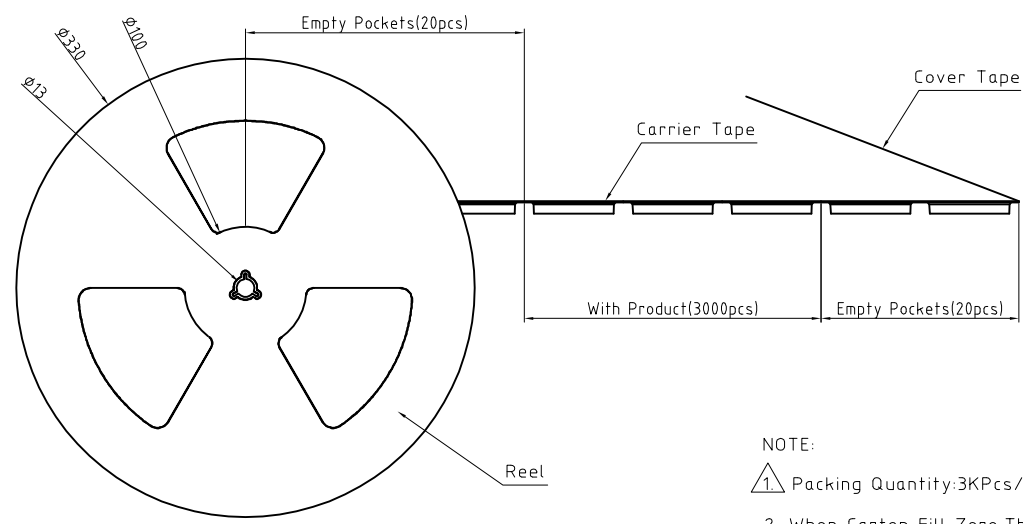
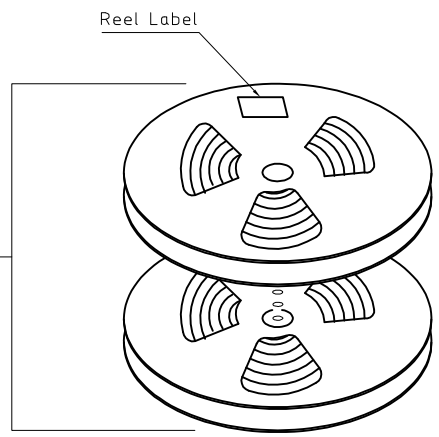

NOTE:
 1. Packing Quantity: 3Kpcs/Reel, 30Kpcs/Carton;
 2. When Carton Fill Zero, Then Fill of Polyethylene Foam;

DO NOT SCALE DRAWING

10	Sealing Tape	/	/	5	Product	30Kpcs /
9	Carton Label	1	/	4	Reel Label	10 /
8	Carton	1	340X340X300	3	Reel	10 Blue,
7	Waterproof Bag	1	/	2	Cover Tape	/ Transparent, Width=21.7mm;
6	Desiccant	2	30g/bag	1	Carrier Tape	/ Transparent, Width=24.0mm;
Item	Part Name	Q'ty	Description	Item	Part Name	Q'ty Description

Packaging Drawing

APPROVED: Jean Long

CHECKED: Jean Long

DRAWING: King Hsu

深圳市普玛斯精密组件有限公司
 SHENZHEN PROMAX EXACTITUDE DISCRETENESS CO.,LTD .

GENERAL TOLERANCES	TITLE: Block Type SIM Card Conn. Core
X: ±0.30	PART NO: MC10B-10030-7F
.XX: ±0.20	DWG NO: DMC10-10030
.XXX: ±0.10	REV: A
ANGEL: ±1°	UNIT: mm
SHEET: 1 / 1	SCALE: /
	SHEET: A4